

A Palpation System for Artery Localization in Laparoscopic Surgery

William J. Peine, Jae S. Son, and Robert D. Howe

Division of Applied Sciences
Harvard University, Cambridge, MA 02138
Tel.: (617) 496-8359, Fax: (617) 495-9837
Email: howe@das.harvard.edu

ABSTRACT: This paper describes a system for finding hidden arteries in remote and inaccessible locations. A tactile array sensor is located in the end of a long, 10 mm diameter probe. In a surgical application, the surgeon presses the sensor against the tissue of interest, and electronics read out the pressure distribution across the contact area at a high rate. A computer captures this information and processes the signal to find the periodic pressure variations due to the pulsatile arterial blood flow. The results are then displayed on a video monitor for the surgeon's use. This device is the first part of a complete remote palpation system that will convey tactile information to the surgeon's finger tips using shape, pressure, and vibration displays.

1. Introduction

Minimally invasive surgical techniques, such as laparoscopy, deprive surgeons of one of their most valuable assets: the sense of touch. We are working towards creating a remote palpation system that will convey tactile information from inaccessible locations to the surgeon's finger tips. This requires the development of appropriate sensors, signal processing algorithms, and tactile "display" devices. The first result of this effort is a system for finding arteries in laparoscopic surgery. Arteries that are hidden beneath opaque tissues often must be carefully located to prevent unintended rupture and life-threatening exsanguination. This requires slow and painstaking dissection with clumsy laparoscopic tools, making these procedures time consuming and tedious.

We have developed a device for artery localization through tactile detection of pulsatile pressure variations. The approach is modeled after the surgeon's ability to locate arteries through palpation in conventional open-incision surgery. In contrast to Doppler ultrasound probes which have also been suggested for this application, our tactile sensors are made with an inexpensive photolithography/etching process and are thus economically disposable after a single use. Our sensing system can also be used in other palpation tasks, such as the detection of

hard inclusions and measurement of the texture of soft structures. Previous work on medical application of tactile array sensors (e.g. Dario 1988) was largely aimed at creating autonomous robotic palpation systems. In contrast, our system is designed to relay to surgeons the sort of information they would receive in direct palpation with their own fingers.

2. System Design

The main components of the system are shown in Figure 1. In a typical laparoscopic procedure, a tactile array sensor located on the end of a probe (Figure 2) is inserted through a conventional 10 mm trocar. The surgeon presses the sensor against the tissue of interest, and electronics read out the pressure distribution across the contact area at a high rate. A computer captures this information and processes the signal to find the periodic pressure variations due to the pulsatile arterial blood flow. The results are then displayed on a video monitor for the surgeon's use.

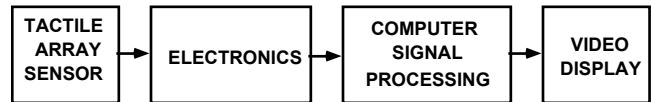

Figure 1. System block diagram.

One important design problem is determining the optimum compliance of the sensor surface to maximize signal amplitude. Solution of this problem requires analysis of the interaction between the sensor and tissue. The artery is essentially an elastic tube, with the blood pressure contained largely by the strength of the arterial wall. To detect arterial pressure through contact, the sensor surface must deflect the wall of the artery and thus assume some of the pressure load. In the simplest case, the artery is modeled as a perfectly flexible membrane, and the force due to the arterial pressure on a flat indenting sensor surface is

$$F(t) = \frac{\pi}{2} \Delta H p(t) \quad (1)$$

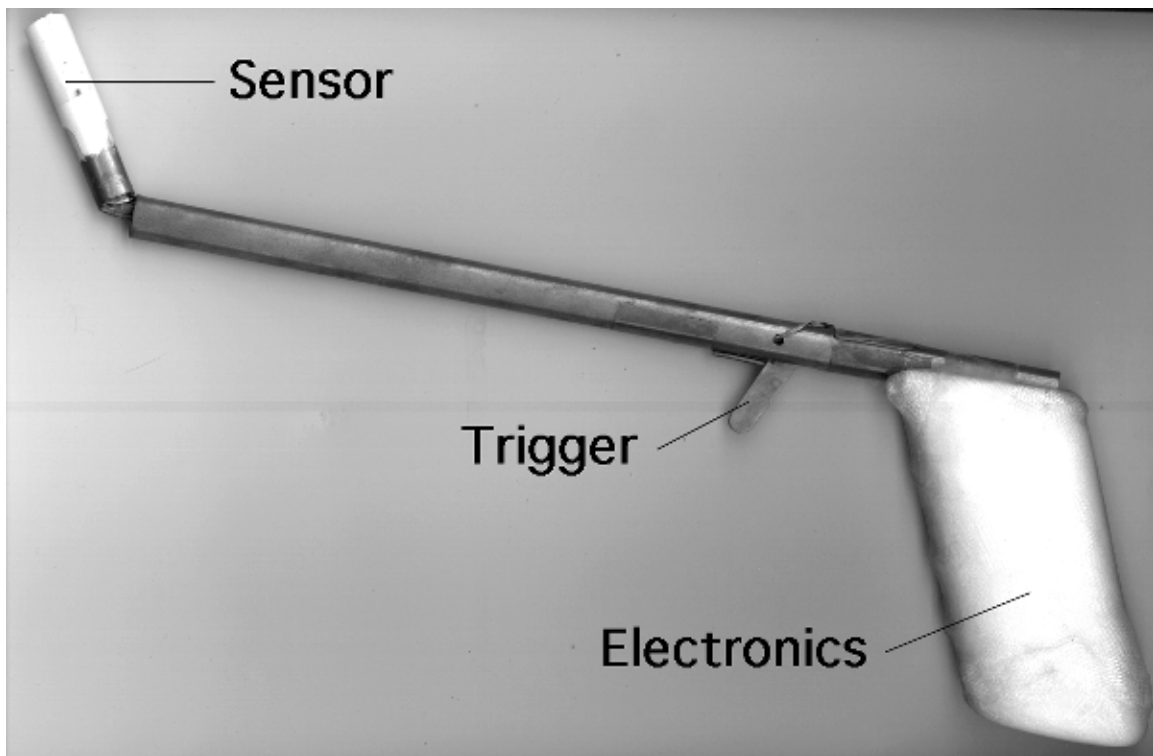

Figure 2. Photograph of "pistol grip" palpation instrument. The surgeon maneuvers the sensor on the tip to the region of interest, then uses the trigger to press the sensor against the structure believed to contain an artery. The low-friction tip joint permits accurate perception and control of the contact force at the sensor surface.

where ΔH is the distance the artery is compressed from its initial diameter and $p(t)$ is the time-varying blood pressure. According to this relation, the measured sensor signal will increase as the artery is compressed (up to the point that flow is restricted). This suggests that a rigid sensor is preferable since it will most effectively compress the artery and surrounding tissue. However, some compliance in the sensor surface is useful as it permits the sensor to conform to geometric and elastic irregularities in the sensed region. The compliance of the sensor surface should thus vary with the physiology in the target tissue region, and sensor surface compliance can be optimized for a particular application.

Figure 3 shows the construction of the tactile array sensor, which is based on an earlier design by Fearing (1990). It is composed of two crossed layers of copper strips separated by thin strips of silicone rubber. As a force is applied to the surface above the point where two strips cross, the distance between the strips decreases, which causes the capacitance between the strips to increase. By measuring the capacitance at each crossing point, the spatial distribution of pressure across the sensor can be determined. Sensitivity of each sensor element is approximately 0.1 gram¹. In this application we used 8 strips at 2 mm spacing in each direction, providing 64 force sensitive elements.

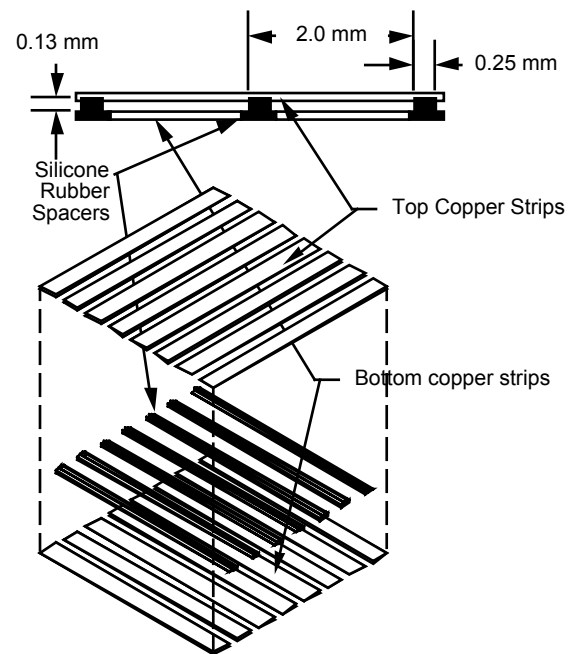

Figure 3. Tactile array sensor. Top: side view; tissue contact occurs on upper surface, compressing silicone rubber and forcing top and bottom copper strips closer together. Bottom: exploded view showing sensor construction.

¹Array sensor response is a function of the details of the applied force distribution; see Fearing (1990).

The sensor forms a thin, compliant layer which can be easily attached to a variety of probe shapes and sizes. By encapsulating the sensor in different elastomers, variable surface compliances can be obtained.

Special-purpose electronics scan the array to measure the capacitance at all elements in 5 msec. A computer samples these force signals 20 times each second; Figure 4(a) shows the force response of a single element located over an artery. Signal processing routines find locations where pulsatile pressure variations are present as well as the relative magnitude of that signal. The current algorithm begins by examining the frequency content of each of the 64 elements, and Figure 4(b) shows the power spectrum of an arterial pulse signal. Since the sensor probe is manually pressed against the area of interest, low frequency noise can obscure the signal in Figure 4. To lessen the effects of these perturbations on the signal of interest, we use the large-amplitude harmonics of the fundamental frequency of the pulse, which range from around two to five Hz for a typical pulse of one Hz. The power in the harmonics is summed at each element, and the relative power is displayed as a two-dimensional contour plot on a video monitor. A more elaborate signal processing scheme now under development takes a trigger signal from an external pulse monitor, and correlates the anticipated pulse waveform with each sensor signal. Advantages of this approach include faster response, better noise rejection, and rapid adaptation to variations in pulse rate.

3. Results

Performance of the system is illustrated by sensing the location of the radial artery in the wrist. Figure 5(a) shows a time sequence of data (with DC component subtracted) taken from a typical localization procedure. Height in each plot represents the force distribution across the array at the particular time indicated. The resulting contour plot showing the location of the artery on the 8x8 array is shown in Figure 5(b). The closed polygons on the plot represent lines of constant detected power of the pulse signal harmonics.

4. System-level design

Although the present system can locate hidden arteries, integration of additional capabilities will enhance functionality in a surgical setting. The present video display shown in Figure 5(b) conveys the required arterial location information, but leaves it to the surgeon to relate the spatial orientation of the display to the placement of the sensor. We are developing an interface that would permit the surgeon to automatically mark the artery location by ejecting ink from the sensor surface once a satisfactory sensor "image" is obtained.

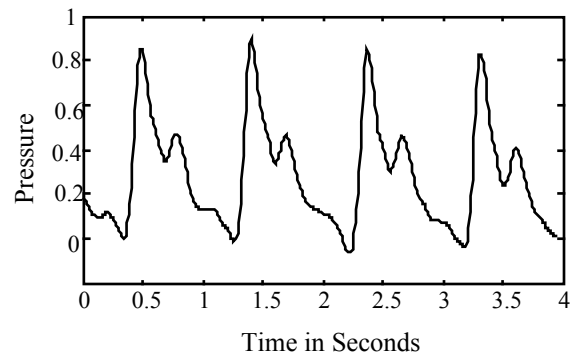

(a)

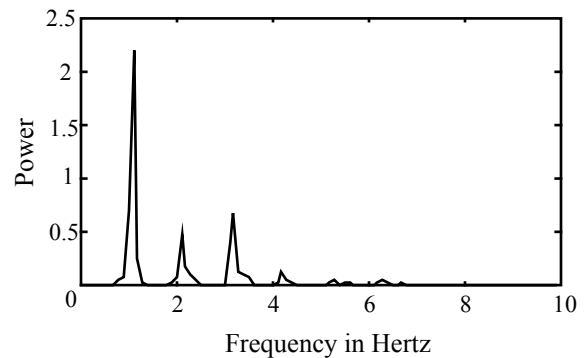

(b)

Figure 4. Force signals from one element of a tactile array sensor located over an artery. (a) Force variation with time. (b) Power spectrum.

Our overall goal is the creation of a complete remote palpation system, and depending on the task the pertinent information can take many forms (pressure variations, stiffness differences, texture variations, etc.). The ultimate feedback device for the entire range of applications is a tactile display that recreates the sensed information on the surgeon's finger tip. We have developed devices for teleoperated manipulation that can relay shape and high-frequency vibrations (Kontarinis and Howe 1993, Howe and Kontarinis 1993). The combination of tactile sensing and tactile feedback can recreate the inaccessible environment, providing a powerful tool for minimally invasive surgery.

Acknowledgments

The authors would like to thank Dr. David Rattner of Massachusetts General Hospital and Dr. Frank Tendick of UCSF for helpful discussions on surgical applications, and Prof. Ronald Fearing of Berkeley for providing electronic circuit designs. The development of the transducer technology described in this report was supported by the Office of Naval Research under Grant No. N-00014-92-J-1814.

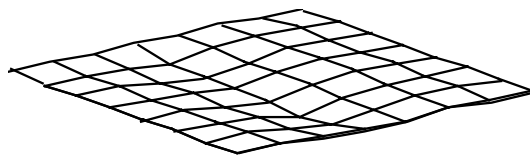

Time = 1.28 Seconds

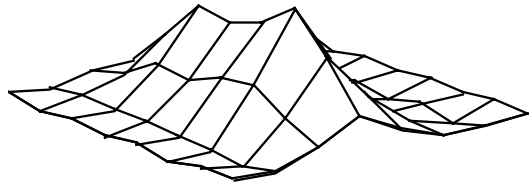

Time = 1.43 Seconds

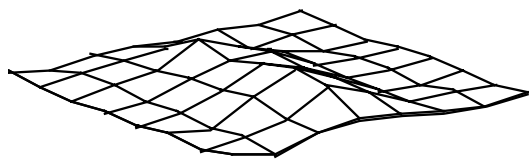

Time = 1.73 Seconds

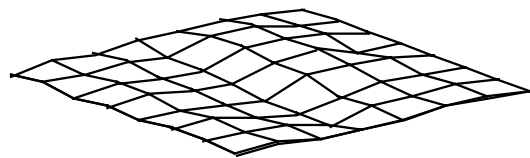

Time = 2.03 Seconds

(a)

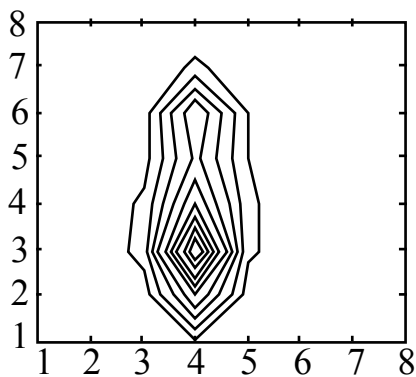

(b)

Figure 5. Arterial localization data. (a) Raw data showing absolute pressure distribution across the contact. The time indicated below each mesh corresponds to the time in the pressure plot in Figure 4. (b) Contour plot display showing artery location; axes refer to sensor element numbers.

References

P. Dario and M. Bergamasco, "An advanced robot system for automated diagnostic tasks through palpation," *IEEE Transactions on Biomedical Engineering*, **35**(2):118-26, Feb. 1988.

R. S. Fearing, "Tactile sensing mechanisms," *International Journal of Robotics Research*, **9**(3):3-23, June 1990.

R. D. Howe and D. A. Kontarinis, "High frequency force information in teleoperated manipulation," Proc. Third International Symposium on Experimental Robotics, Kyoto, Japan, Oct. 28-30, 1993, Springer-Verlag, in press.

D. Kontarinis and R. D. Howe, "Tactile display of contact shape in dextrous manipulation," in *Advances in Robotics, Mechatronics, and Haptic Interfaces*, DSC-vol. 49, H. Kazerooni, J. E. Colgate, and B. D. Adelstein, eds., American Society of Mechanical Engineers Winter Annual Meeting, New Orleans, Nov. 29-30, 1993, pp. 81-88.